

FAAC XGUARD-10/-5

LASER SCANNERS FOR INDUSTRIAL DOORS

XGUARD-10: max. detection range of 9.9 m x 9.9 m

XGUARD-5: max. detection range of 5.0 m x 5.0 m

User's Guide for product version 0600 and more

SAFETY



The device contains IR and visible laser diodes.
IR laser: wavelength 905nm; max. output pulse power 75W (Class 1 according to IEC 60825-1)
Visible laser: wavelength 650nm; max. output CW power 3mW (Class 3R according to IEC 60825-1)

The visible laser beams are inactive during normal functioning.
The installer can activate the visible lasers if needed.



CAUTION!

Use of controls, adjustments or performance of procedures other than those specified herein may result in hazardous radiation exposure.

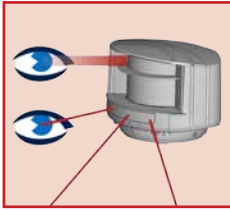

Do not look into the laser emitter or the visible red laser beams.

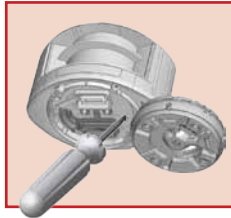

The warranty is void if unauthorized repairs are made or attempted by unauthorized personnel.



Only trained and qualified personnel may install and adjust the sensor.



Test the good functioning of the installation before leaving the premises.

The manufacturer of the door system is responsible for carrying out a risk assessment and installing the sensor and the door system in compliance with applicable national and international regulations and standards on door safety and if applicable, the machinery directive 2006/42/EC. Other use of the device is outside the permitted purpose and can not be guaranteed by the manufacturer. The manufacturer cannot be held responsible for incorrect installations or inappropriate adjustments of the sensor.

INSTALLATION AND MAINTENANCE

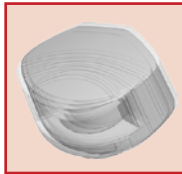

Avoid extreme vibrations.

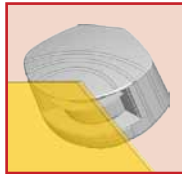

Do not cover the front screens.

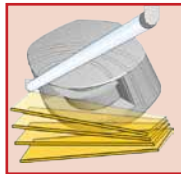

Avoid moving objects and light sources in the detection field.



Avoid the presence of smoke and fog in the detection field.

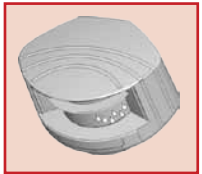

Avoid condensation.

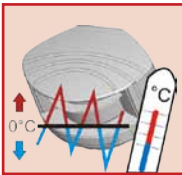

Avoid exposure to sudden and extreme temperature changes.



Avoid direct exposure to high pressure cleaning.



Do not use aggressive products to clean the front screens.

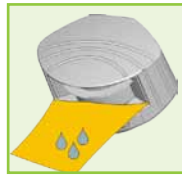

Wipe the front screens regularly with a clean and damp cloth.

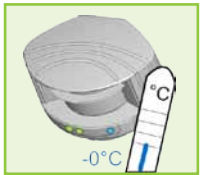

Keep the sensor permanently powered in environments where the temperature can descend below -10°C.

DESCRIPTION

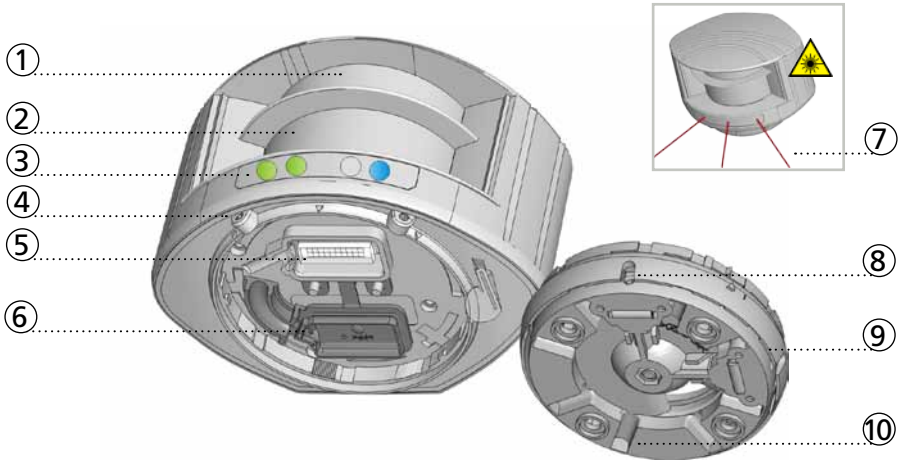

- | | |
|--------------------------------|--|
| 1. laser sweep emission | 6. protection cover |
| 2. laser sweep reception | 7. visible laser beam (3) |
| 3. LED-signal (4) | 8. notch for tilt angle adjustment (2) |
| 4. screw for position lock (2) | 9. adjustable bracket |
| 5. connector | 10. cable conduit (4) |

LED-SIGNAL

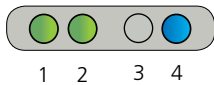

1. Detection LED: relay 1 - optional field
2. Detection LED: relay 2 - safety field
3. Error LED
4. Power LED

DETECTION LEDs

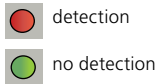

ERROR LED

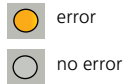

POWER LED

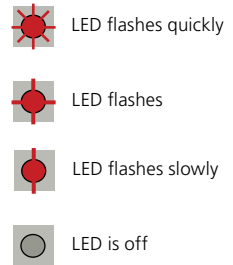
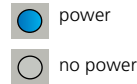

TIP! All LEDs can be switched off and on again by remote control:



SYMBOLS



Caution!
Laser radiation

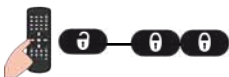

Remote control
sequence



Possible
remote control
adjustments



Factory
values



EN ISO 13849-1:2008
PI «d» / CAT2



1 MOUNTING

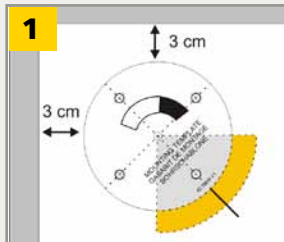
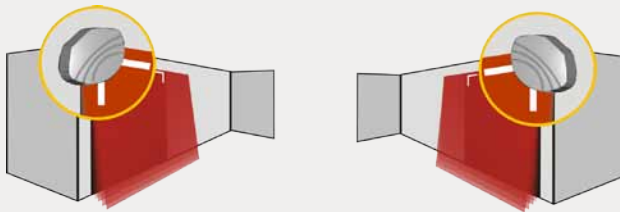

Use the adhesive mounting template to position the sensor correctly. The grey area indicates the detection range.

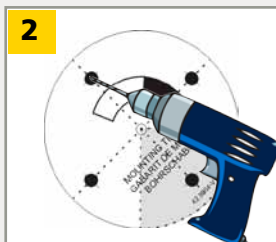

Drill 4 holes as indicated on the mounting template. Make a hole for the cable if possible.

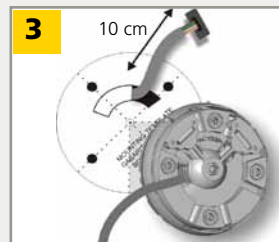

Pass the cable +/- 10 cm through the cable opening. If drilling an opening is not possible, use the cable conduits on the back side of the bracket.



Position the bracket and fasten the 4 screws firmly in order to avoid vibrations.



Open the protection cover, plug the connector and position the cable in the slit.



Close the protection cover and fasten it firmly.

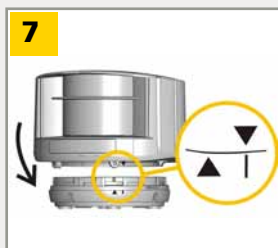

Position the housing on the bracket.

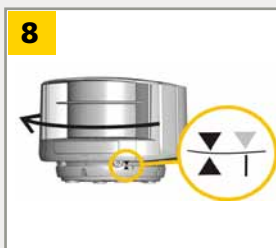

Turn the sensor until the two triangles are face to face.

2 WIRING

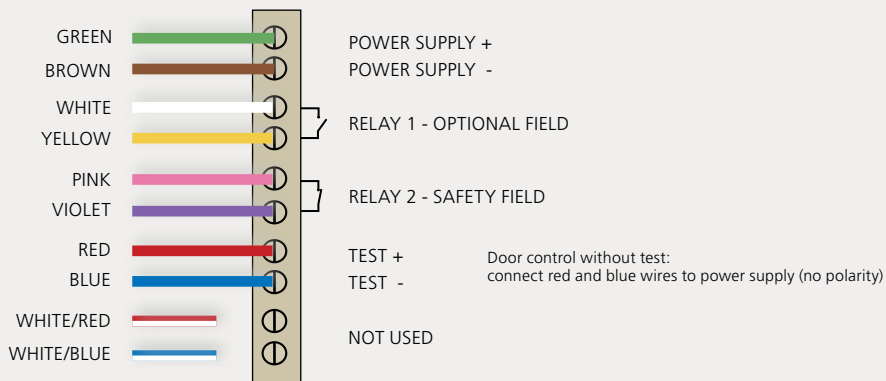

3 POSITIONING



Unlock the sensor and activate the visible laser beams.

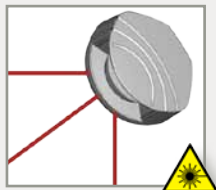

The visible laser beams indicate approximately the position of curtain C1 and the angle of the detection field.

The visible laser beams stay activated for 15 minutes or can be turned off the same way they were activated.

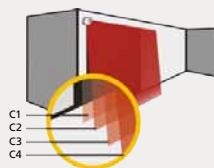

Adjust the **lateral position** of the detection field.



Adjust the **tilt angle** of the detection field with the hex key.

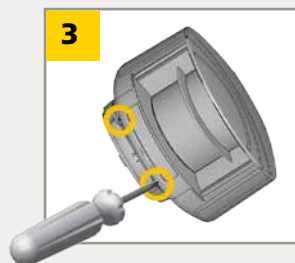

Lock the position of the mounting bracket to avoid malfunctioning in case of extreme vibrations.

CAT 2

CAUTION!

The distance between the inner curtains of the 2 sensors must be max. 20 cm.



4 MOUNTING SIDE

Stay outside of the detection field to avoid disturbances.

Select the corresponding mounting side.

The sensor learns its environment and automatically determines the detection field(s).

Both RED LEDs flash slowly and the 3 visible laser beams automatically light up during 30 seconds.



WITH BACKGROUND

The sensor memorizes the floor as reference point and signals a fault when its orientation is changed.

WITHOUT BACKGROUND

No reference point, no signal.

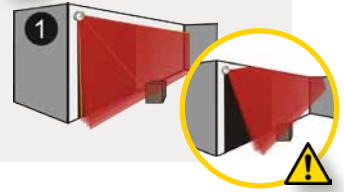

5 SAFETY FIELD DIMENSIONS

	XGUARD-10			XGUARD-5		
	WIDTH	MIN	MAX	MIN	MAX	
	00	05	99	00	05	50
	no field	0.5 m	9.9 m	no field	0.5 m	5.0 m
HEIGHT			5.0 m			5.0 m
	05	99		05	50	
	0.5 m	9.9 m		0.5 m	5.0 m	

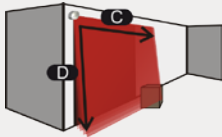

EXAMPLE for a field width of 6.2 m

IMPORTANT: Test the good functioning of the installation before leaving the premises.

TEACH-IN

Launch a teach-in after changing the sensor position or when new objects are added to or changed in the detection zone.

The detection field should be free of snow buildups, heavy rain, snowfall, fog or other moving objects.



During teach-in, the sensor learns its surroundings and adapts the detection field shape to these. Objects in the detection field will be cut out.

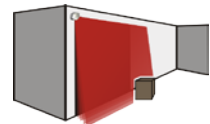

REMOTE CONTROL ADJUSTMENTS (OPTIONAL)

DETECTION CURTAINS

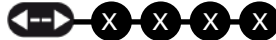
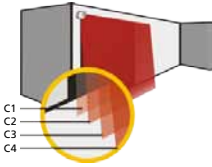

CURTAIN C1 C2 C3 C4

- 0 deactivate curtain on both fields
- 1 activate curtain only on optional field
- 2 activate curtain only on safety field
- 9 activate curtain on both fields



EX: C1 + C2 active on optional field only
C3 + C4 active on safety field only



C1 active on both fields
C2+C3 active on safety field only
C4 deactivated



All curtains active on both fields

The distances between the curtains depend on the mounting height and side. When mounted on the left, the distance between the first and the last curtain is approximately 10 cm for every meter (mounting height). **Example:** at 5 m the distance is 50 cm.

UNCOVERED ZONE

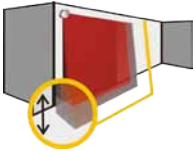

5 10 15 20 25 cm



Increase in case of snow, dead leaves, etc.

IMMUNITY FILTER



indoor outdoor low outdoor med outdoor high indoor outdoor low outdoor med outdoor high



Increased immunity to rain, snow, fog...

Increased sensitive (detection of black objects, ...)

MIN. OBJECT SIZE (approximate values)



off 5 10 15 20 cm



OUTPUT ACTIVATION DELAY (approximate values)



off 100 200 300 400 500 600 700 800 900 ms

The outputs are triggered after a constant detection time of x ms (ex. value 3 = 300 ms).

DETECTION FIELD REDIRECTION



R1 optional optional or safety
R2 safety safety

OUTPUT CONFIGURATION

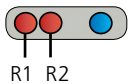

R1 A - NO P - NC P - NC A - NO
R2 P - NC A - NO P - NC A - NO

A = active
P = passive
NO = normally open
NC = normally closed

FACTORY VALUES

Rx = RELAY OUTPUT

OPTIONAL FIELD CONFIGURATIONS

Make sure the white and yellow wires are connected to the corresponding inputs before you choose one of the following two configurations.

VIRTUAL PUSH BUTTON



Install 1 or 2 virtual push buttons as activation zone(s) to open the door «manually».

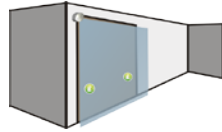

1 Apply the virtual push button sticker(s) **within the opening field.**

2 Launch a PB teach-in to configure the detection zone(s). Launch a new PB teach-in each time the sensor position is changed or new objects are added to or changed in the detection zone. **ATTENTION!** This PB teach-in is different from the safety field teach-in.

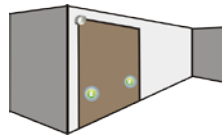

When the red LED flashes very slowly after 3 seconds, hold your hand in front of the sticker to learn the detection zone. The green LED flashes 3x to confirm the selection. When the red LED flashes again, learn a second (max. 2) detection zone or wait until the LED switches to green.

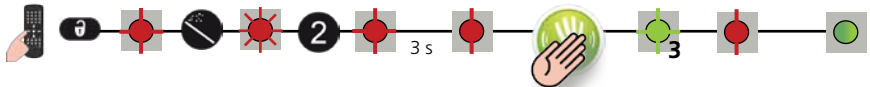

3 Change the output redirection if needed.

In order to cancel the virtual push button function, you have to launch a new PB teach-in without any movement in the detection field. Only then the safety-during-opening can be configured.

OR SAFETY-DURING-OPENING



Configure a second detection field to secure the door during opening.

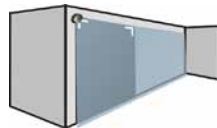

1 After setting the mounting side, the safety and the optional field will have the same dimensions.

2 Adjust the size of the field by remote control.

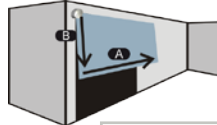

3 Change the output redirection if needed.

		XGUARD-10			XGUARD-5		
WIDTH		00	05 - 99	00	05 - 50		
		same as safety field	0.5 m	9.9 m	same as safety field	0.5 m	5.0 m
HEIGHT		00	05 - 99	00	05 - 50		
		no field	0.5 m	9.9 m	no field	0.5 m	5.0 m

HOW TO USE THE REMOTE CONTROL



After unlocking, the red LED flashes and the sensor can be adjusted by remote control.



If the red LED flashes quickly after unlocking, you need to enter an access code from 1 to 4 digits.



To end an adjustment session, always lock the sensor.

ADJUSTING ONE OR MORE PARAMETERS

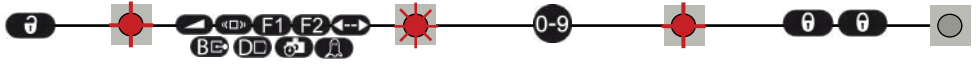

CHECKING A VALUE

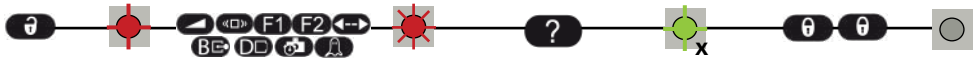

= field width: 4.2 m

= field width is defined by teach-in

RESTORING TO FACTORY VALUES

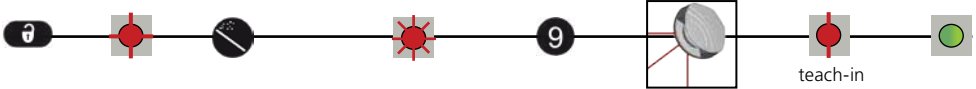

SAVING AN ACCESS CODE

The access code is recommended for sensors installed close to each other.



DELETING AN ACCESS CODE

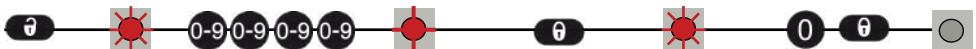

Enter the existing code

30 minutes after last use, the sensor locks the access to the remote control session.
Cut and restore power supply. The remote control session is accessible again during 30 minutes.

X = NUMBER OF FLASHES = VALUE OF THE PARAMETER

TROUBLESHOOTING

	No blue LED	<p>There is no power.</p> <p>The polarity of the power supply is inverted.</p> <p>All LEDs have been deactivated by remote control.</p>	<p>1 Check cable and connexion.</p> <p>1 Check the polarity of the power supply.</p> <p>1 Activate the LEDs by remote control.</p>
	Only the blue LED is on.	The test input is not connected.	<p>1 Check wiring. The RED and BLUE cable have to be connected to the test input or the power supply.</p>
	The detection LED remains green.	The detection field is too small or deactivated.	<p>1 Check the size of the fields.</p> <p>2 Launch a teach-in.</p>
	The detection LED remains red.	The object size is too small.	<p>1 Decrease the min. object size.</p>
	The detection LED remains red.	Someone or something is in the detection field.	<p>1 Step out of the field and/or remove the any object(s) from the field.</p>
	The detection LED remains red.	The field is touching the floor, the wall or the door, which leads to detection.	<p>1 Activate the 3 red beams and check if the position of the sensor is correct. If not, adjust the hex screws.</p>
	The orange LED is flashing and the detection LEDs are red.	The field is touching the floor, the wall or the door, which leads to detection.	<p>2 Verify the field size.</p> <p>3 Launch a teach-in.</p>
	The orange LED is flashing and the detection LEDs are red.	No background (reference point) is found.	<p>1 Check the position of the sensor.</p> <p>2 Check the mounting side setting. If there is no background, set the mounting side to value 3 to 5.</p>
	The orange LED is flashing and the detection LEDs are red.	The sensor is masked.	<p>3 Launch a new teach-in.</p> <p>1 Verify and clean the front screens with a damp cloth.</p>
	The orange LED is on.	The power supply voltage is exceeding the acceptable limits.	<p>1 Check the power supply voltage.</p>
	The orange LED is on.	The sensor exceeds its temperature limits.	<p>1 Verify the outside temperature where the sensor is installed. Eventually protect the sensor from sunlight using a cover.</p>
	The orange LED is on.	Internal error	<p>1 Wait a few seconds. If the LED remains ON, reset the power supply. If the LED turns on again, replace the sensor.</p>
	The sensor does not respond to the remote control.	30 minutes after last use of the remote control, the sensor locks the access to the remote control session.	<p>1 Cut and restore power supply. The remote control session is accessible again during 30 minutes.</p>
	The sensor does not respond to the remote control.	The batteries in the remote control are not installed properly or dead.	<p>1 Verify or replace the batteries.</p>
	The sensor does not respond to the remote control.	The remote control is badly pointed.	<p>1 Point the remote control towards the sensor, but with a slight angle. The RC should not be pointed in a right angle in front of the sensor.</p>
	The sensor does not respond to the remote control.	A reflective object is in close proximity to the sensor.	<p>1 Avoid highly reflective material in proximity to the sensor.</p>
	The sensor does not unlock.	You have to enter an access code or the wrong code was entered.	<p>1 Cut and restore power supply. No code is required to unlock during the first minute after powering.</p>

TECHNICAL SPECIFICATIONS

Technology:	laser scanner, time-of-flight measurement
Detection mode:	motion and presence (EN 12453 Typ. E)
Max. detection range:	XGUARD-10: 9.9 m x 9.9 m; XGUARD-5: 5.0 m x 5.0 m
Remission factor:	> 2 %
Angular resolution:	0,3516 °
Min. detected object size (typ.): (in proportion to object distance)	XGUARD-10: 2,1 cm @ 3 m ; 3,5 cm @ 5 m ; 7 cm @ 10 m XGUARD-5: 2,1 cm @ 3 m ; 3,5 cm @ 5 m
Testbody:	700 mm x 300 mm x 200 mm (testbody A according to EN 12445)
Emission characteristics:	
IR laser:	wavelength 905 nm; max. output pulse power 75 W (CLASS 1)
Red visible laser:	wavelength 650 nm; max. output CW power 3 mW (CLASS 3R)
Supply voltage:	10-35 V DC @ sensor side
Power consumption:	< 5 W
Peak current at power-on:	1.8 A (max. 80 ms @ 35 V)
Cable length:	10 m
Response time:	typ. 20 ms; max. 80 ms (+ output activation delay)
Output:	2 electronic relays (galvanic isolated - polarity free)
Max. switching voltage:	35 V DC / 24 V AC
Max. switching current:	80 mA (resistive)
Switching time:	t _{ON} =5 ms; t _{OFF} =5 ms
Output resistance:	typ 30 Ω
Voltage drop on output:	< 0.7 V @ 20 mA
Leakage current:	< 10 µA
Input:	2 optocouplers (galvanic isolated - polarity free)
Max. contact voltage:	30 V DC (over-voltage protected)
Voltage threshold:	Log. H: >8 V DC; Log. L: <3 V DC
Response time monitoring input:	< 5 ms
LED-signal:	1 blue LED: power-on status 1 orange LED: error status 2 bi-coloured LEDs: detection/output status (green: no detection; red: detection)
Dimensions:	125 mm (D) x 93 mm (W) x 70 mm (H) (mounting bracket + 14 mm)
Material:	PC/ASA
Colour:	black or white
Mounting angles on bracket:	-45 °, 0 °, 45 °
Rotation angles on bracket:	-5 ° to +5 ° (lockable)
Tilt angles on bracket:	-3 ° to +3 °
Protection degree:	IP65
Temperature range:	-30 °C to +60 °C if powered; -10 °C to +60 °C unpowered
Humidity:	0-95 % non-condensing
Vibrations:	< 2 G
Pollution on front screens:	max. 30 %; homogenous
Expected lifetime:	20 years
Norm conformity:	2006/95/EC: LVD; 2002/95/EC: RoHS; 2004/108/EC: EMC; 2006/42/EC: MD; EN 12453:2000 chapter 5.1.1.6, chapter 5.5.1 Safety device E; EN 12978:2009; EN ISO 13849-1:2008 PL "d"/ CAT2; EN 60529:2001; IEC 60825-1:2007; EN 60950-1:2005; EN 61000-6-2:2005; EN 61000-6-3:2006; IEC 61496-1:2009; EN 61496-3:2008 ESPE Type 2; EN 62061:2005 SIL 2; DIN 18650-1:2010 Chapter 5.7.4

Specifications are subject to changes without prior notice.
All values measured in specific conditions.

PLEASE KEEP FOR FURTHER USE
DESIGNED FOR COLOUR PRINTING

©BEA | Original instructions | 42.8058 / V1 - 07.13

FAAC S.p.A . - Via Calari, 10 40069 Zola Predosa - Italia - tel. +39 051 61724 - fax. +39 051 758518 - www.faacgroup.com



BEA hereby declares that the FAAC XGUARD-10/-5 is in conformity with the basic requirements and the other relevant provisions of the directives 2006/95/EC, 2002/95/EC, 2004/108/EC and 2006/42/EC.

Notified Body for EC inspection: 0044 - TÜV NORD CERT GmbH, Langemarckstr. 20, 45141 D-Essen

Angleur, July 2013

Pierre Gardier, Authorized representative and responsible for technical documentation



For EC countries: according to the directive 2002/96/EC for Waste Electrical and Electronic Equipment (WEEE)